

INSTALLATION INSTRUCTIONS

ITEM #ST2W

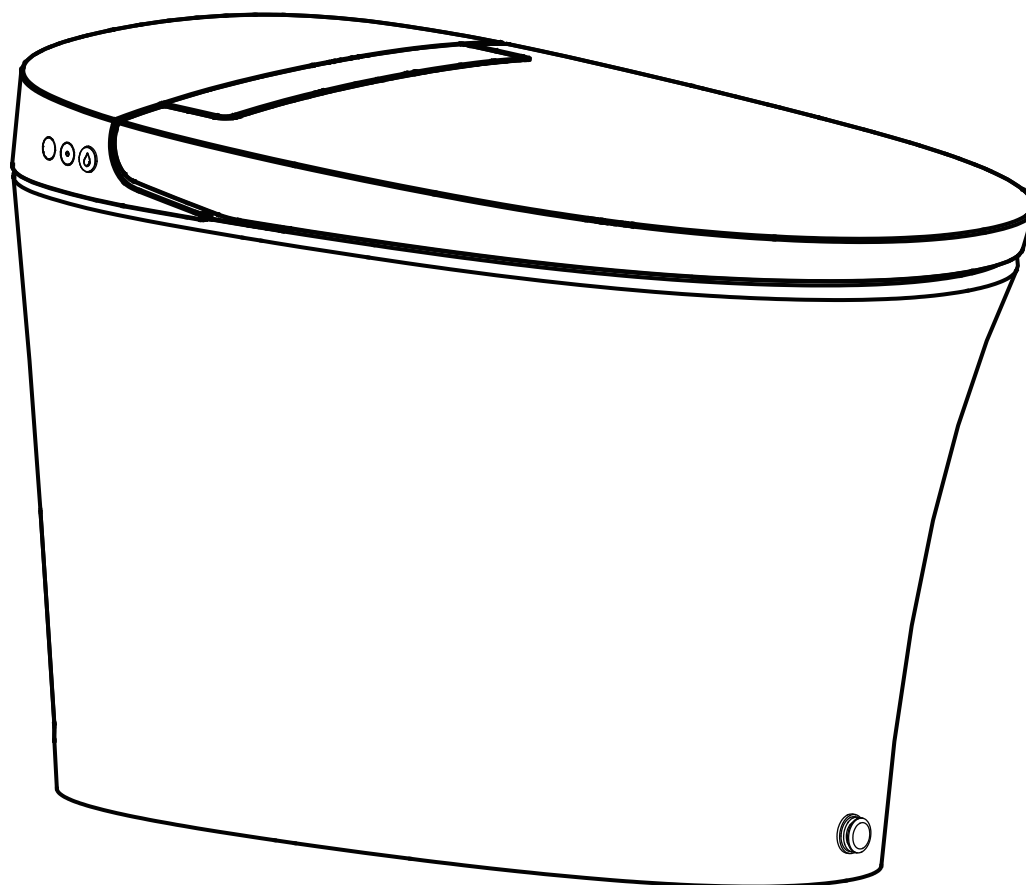

SMART TOILET

Content

Installation

Safety instructions	01
List of materials	03
Technical drawings	04
Parts identification	05
Installation of ceramic toilet	06
Before Installation	08

Maintenance

Daily maintenance	12
1. Main unit care and maintenace	
2. Maintenance of filter net	
Emergency troubleshooting	13
1. Electricity and water supply cut-off	
2. Replacement of battery	
3. Low voltage battery determination and replacement	
4. When the product is left unused for long time	

Others

Technical specification	15
The illustration of Main unit Buttons	16

⚠️ READ ALL INSTRUCTIONS BEFORE UNPACKING THE PRODUCT

INSTRUCTIONS THAT, IF IGNORED COULD RESULT IN DEATH OR SERIOUS INJURY CAUSED BY INCORRECT HANDLING OR INSTALLATION OF THE PRODUCT. THESE INSTRUCTIONS MUST BE OBSERVED FOR SAFE INSTALLATION.

CAUTION!  **TWO PERSON LIFT REQUIRED**

2 PEOPLE ARE REQUIRED TO LIFT AND DURING ENTIRE INSTALLATION OF THIS PRODUCT





⚠️ INSTALLATION OF THIS PRODUCTS BY AN INEXPERIENCED INSTALLER MAY RESULT PERSONAL INJURY OR DEATH! ⚠️

We reserves the right to change, update, modify, altar, redesign this manual/product or its policies without prior notice!
It is your responsibility to visit website to download or contact customer service for the most updated version of the installation instructions.
We shall not be liable for any injuries or property damages in connection with this product during inataliation or use of this product!

- * LIMITED WARRANTY IS VOID ON ANY COMMERCIAL INSTALLATION.
- * WE ARE NOT RESPONSIBLE FOR LOCAL CODE COMPLIANCE FOR THIS PRODUCT.
- * BUILDING AND PLUMBING CODES MAY VARY FROM STATE-TO-STATE IN ACCORDANCE TO YOUR LOCATION.
- * WE ARE NOT RESPONSIBLE FOR PROVIDING ANY COMPLIANCE CERTIFICATIONS.
- * WE ARE NOT RESPONSIBLE TO PROVIDE ANY TYPE OF CERTIFICATIONS FOR THIS PRODUCT.
- * UNDER NO CIRCUMSTANCES WE SHALL NOT BE LIABLE FOR ANY AND ALL INCIDENTAL DAMAGES SUSTAINED IN CONNECTION WITH THIS PRODUCT NEITHER MANUFACTURE, NOR DISTRIBUTOR, NOR RETAILER 1S RESPONSIBLE FOR WATER DAMAGE OR FLOOD CAUSED DUE TO USE OF THIS PRODUCT.
- * UNDER NO CIRCUMSTANCES WE SHALL NOT BE LIABLE FOR ANY AND ALL FEES, COST OF INSTALLATION/REINSTALLATION/REMOVAL, SUBSEQUENT DAMAGE OR TRANSPORTATION IN CASE OF THE PRODUCT DEFECT.

VANITY COMPONENTS AND HARDWARE

DURING UNPACKING THE PRODUCT AND PRIOR TO INSTALLATION INSPECT YOUR NEW PRODUCT FOR ANY DAMAGES OR MISSING PARTS. DO NOT ATTEMPT TO INSTALL OR OPERATE THE PRODUCT IF THE PRODUCT IS DAMAGED.

Part A		6 Pieces
Part B		6 Pieces
Part C		6 Pieces
Part D		4 Pieces
Part E		16 Pieces

TOOLS REQUIRED FOR INSTALLATION

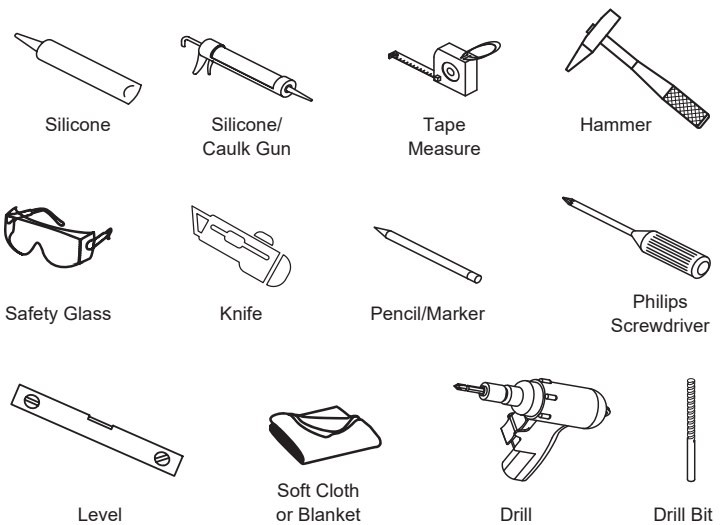



OTHER TOOLS MAY BE REQUIRED*

Safety instructions



Please read the instructions carefully before installation and keep it available for future maintenance or reference.





Failure to follow these instructions can cause body injury and property damage.





Symbol Illustration

 Warning	Indicates that failure to follow the instruction may cause serious injury or fatality.
 Caution	Indicates that failure to follow the instruction may cause body injury or property damage.

Symbol Illustration

Symbol	Indication
	Prohibited activities
	Mandatory activities

 Warning	
	Do not throw cigarettes and other burning stuff into toilet, otherwise it might cause malfunction.
	<p>Do NOT disassemble, repair or modify this product by yourself, otherwise it may cause fire or malfunction.</p> <p>Do NOT pour water or detergent on the main unit or battery box plug, otherwise it may cause fire or electric shock.</p> <p>Do NOT handle the battery box plug with wet hands, otherwise it may cause malfunction.</p> <p>This product is factory equipped with a specific battery device. Do NOT use any battery device other than the factory equipped battery device, otherwise it may cause fire or malfunction.</p> <p>If the electric cord of battery box is damaged, it must be replaced by the manufacturer, its service center or equivalent specialist to avoid malfunction.</p> <p>This product is an electric appliance, avoid direct contact with water or other liquids.</p> <p>Do not position the product on its side or upside down while making electrical connections with the battery box, otherwise it may cause fire or burning.</p>
 Mandatory activities	Do not install or use the product in wet or damp locations such as a steam room.

 Warning	
 Mandatory activities	<p>Only use the factory equipped battery box and 1.5V "AA" alkaline battery.</p> <p>When moving the product from a cold or humid environment to normal room temperature, please wait for 2 hours until the condensed water is completely volatilized to prevent electrical short-circuiting of the product.</p>
 Caution	
	<p>Do not place or store product where it can fall or be pulled into a tub or sink.</p> <p>Do not place in or drop into water or other liquid.</p> <p>Do NOT reach for a product that has fallen into water. Unplug the battery box immediately.</p> <p>Do not stand on the ceramic toilet. Do not hit the ceramic. A heavy impact on ceramic leads to damage and water leakage.</p> <p>Never embed ceramic toilet base in cementitious material (such as cement mortar). It may lead to expansion crack.</p> <p>Do not stand on ceramic toilet bowl, seat and cover.</p> <p>Do not use varnish thinners, gasoline, liquid chemicals, detergents, insecticides, toilet cleaners and scrubbing brush to clean the product.</p> <p>Only use tap water or potable water; otherwise it may cause chafing.</p> <p>Exposure to direct sunlight is prohibited.</p> <p>This product is equipped with soft-closing seal cover. Heavy pressing or pushing may damage the soft-closing damper.</p> <p>Do not connect water supply to heater outlet. Make sure inlet water temperature at 3~35 C, exceeding the specified range will result in the built-in heating module not working.</p> <p>Do not lean against the seat cover when using the product to avoid damage.</p> <p>Do not try flushing the newsprint, diapers, sanitary napkins and other items down the toilet, which may result in toilet clogging.</p> <p>If this product is malfunctioning, stop using immediately, unplug the battery box, turn off water supply, and contact the service provider.</p>
 Mandatory activities	<p>Before installation, disassembly, repair and maintenance of the product, the power plug must be unplugged and the water supply valve must be closed.</p> <p>Do not use in an environment below 0 °C.</p> <p>If this product will not be used for an extended period of time (over 3 days), it is recommended to unplug the battery box, remove batteries, turn off water supply, and drain any water in the product.</p> <p>When using electrical products, especially when children are present, basic safety precautions should always be followed, including the following:</p> <ol style="list-style-type: none"> 1. This product is not intended for children (without proper adult supervision). 2. This product is not intended for individuals with reduced physical, sensory, or mental capabilities. <p>To prevent damage caused by freezing, please implement warmth measures to increase the temperature of the toilet.</p>

List of materials

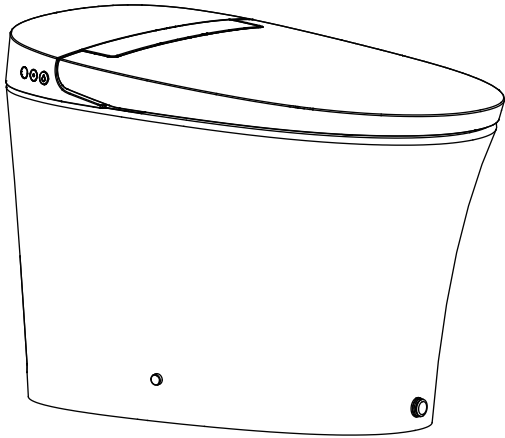

Main Unit

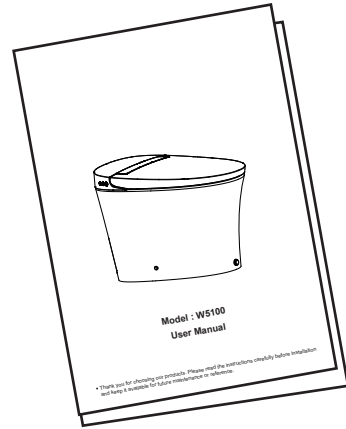

Installation Manual

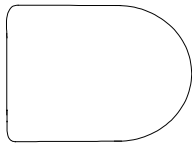

Installation Cardboard

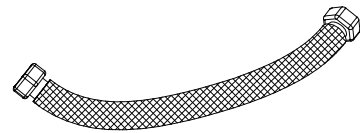

Braided Hose



Sealing Flange

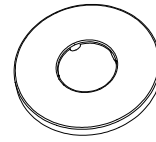

Flange

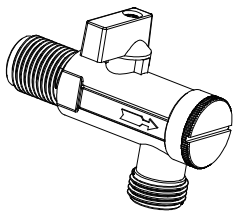

Angle Valve

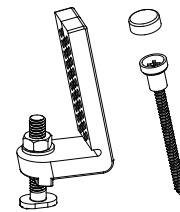

Mounting Accessory Kit

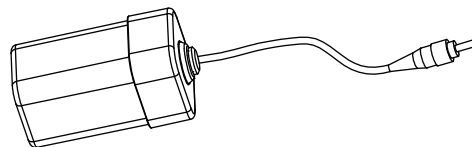

Battery Box

Technical Drawing

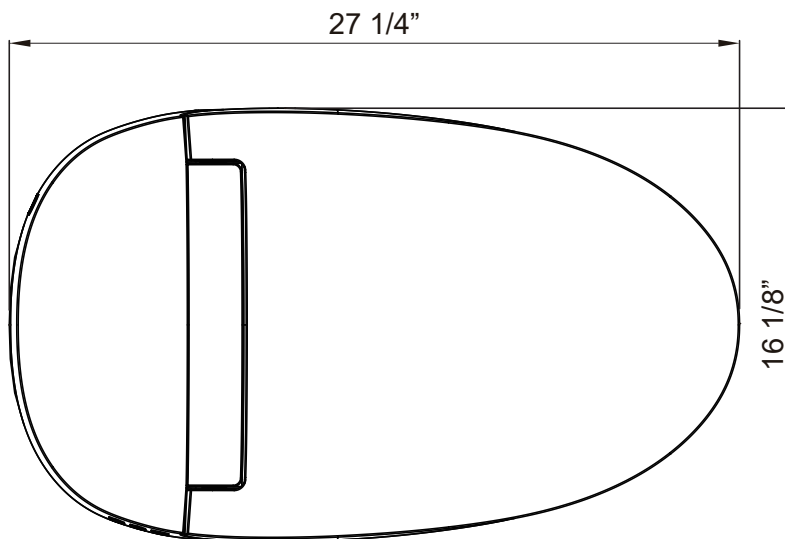
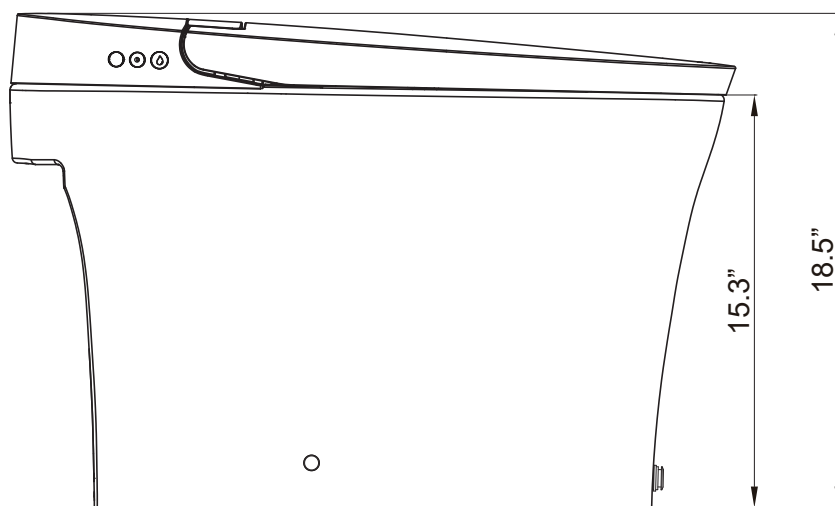

The product drawings are for reference only, and the company reserves the right to modify the appearance of the product without notice.

Parts Identification

Left Side

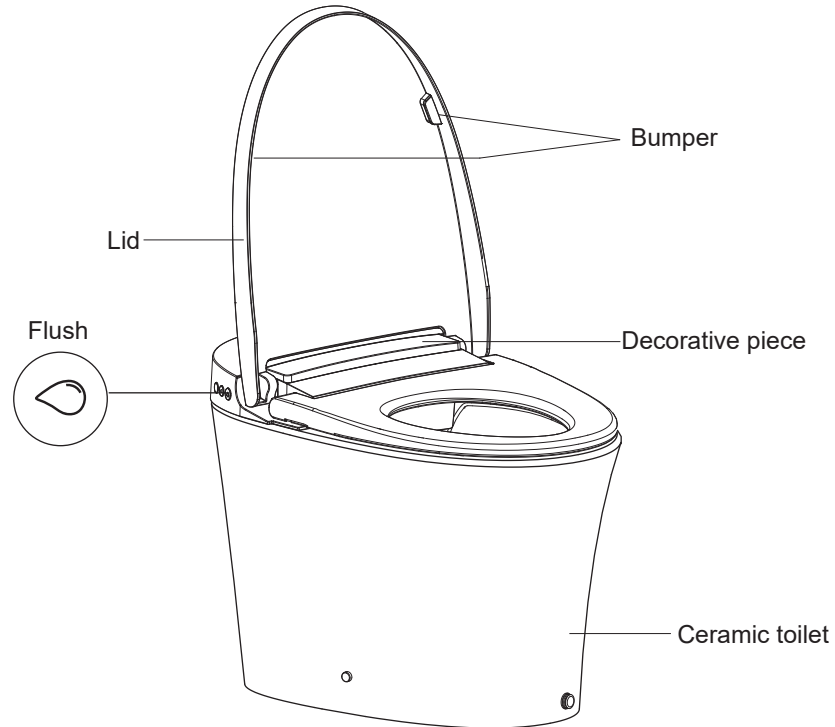

Right Side

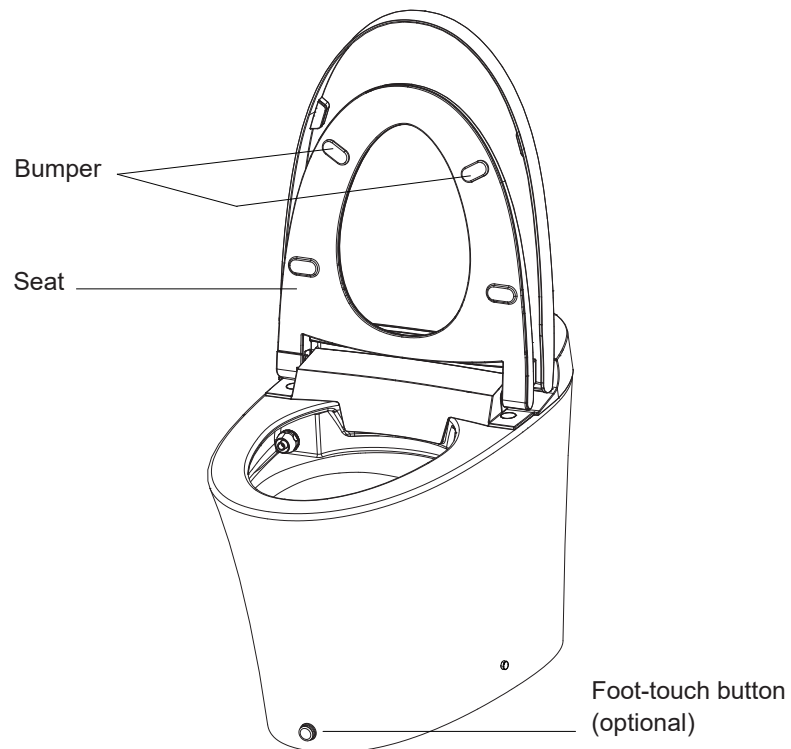

Ceramic Toilet Installation

Caution before installing

- Minimum dynamic working water pressure: 0.09MPa or more (15.0L/min or more), failure to meet this pressure will not achieve the best flushing effect.

Remark: Apply the methods below if you don't have water pressure testing device.

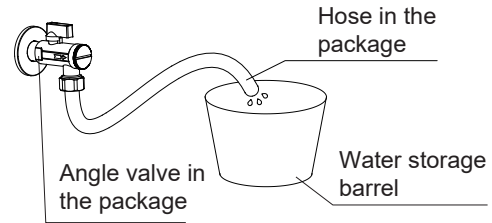

Open the angle valve and connect water inlet for 10s, once the water volume is above 2.5L, the minimum water pressure of the product is ensured.

1. Installation of mating angle valve

- Draw drain outlet centerline on the floor, Install angle valve at proper position on wall according to dimension of toilet.

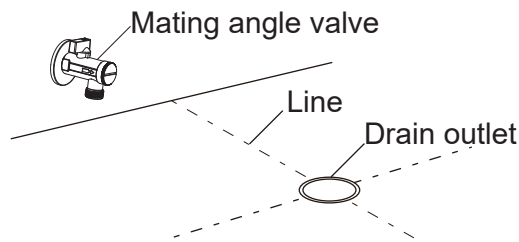

2. Cardboard installation

- Align cardboard with the centerline of drain outlet;
- Draw contour line according to cardboard;

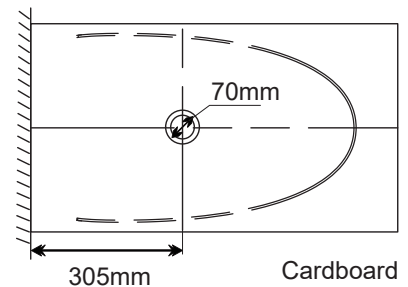

3. Hose

- Connect the water inlet and angle valve of the toilet with the matching hose and tighten it

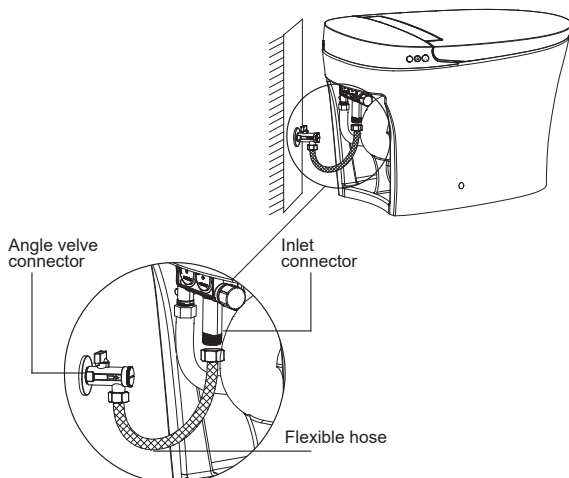

4. Mounting bracket installation

- Assemble the mounting bracket with bolts and then install them to the pre-installed flange plate on the ground and lock tight with nuts.

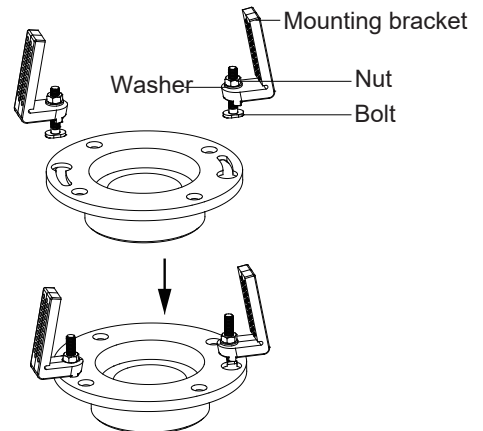

5. Ceramic toilet installation

- Install sealing flange into drain outlet; Install ceramic toilet on corresponding position according to contour line.

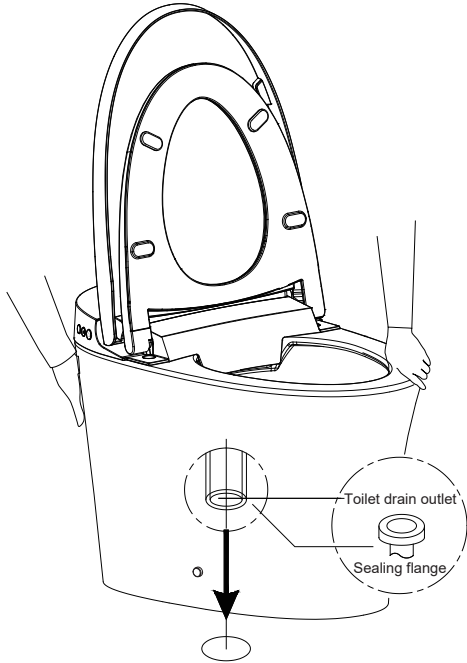

6. Screw installation

- Put the screw through the fixing sleeve and then install it through the holes (on both sides of the toilet ceramic) to the mounting bracket on the ground, and lock tight with a tool;
- Put the decorative cap on the fixing sleeve.

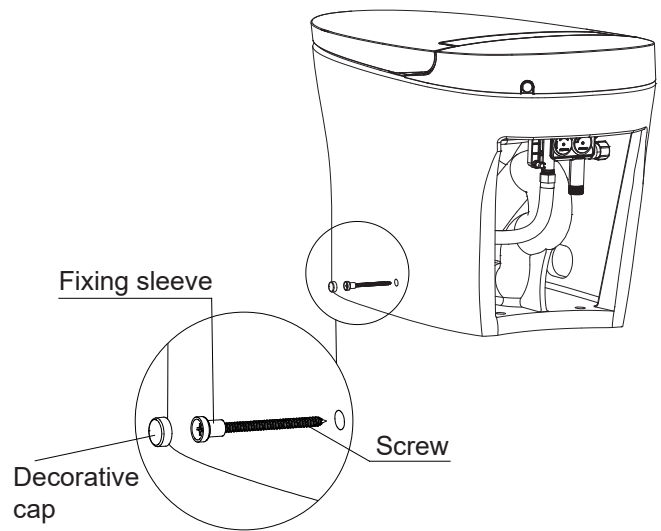

7. Glass cement application

- Apply high quality mildew glass glue around the lower edge of the toilet.

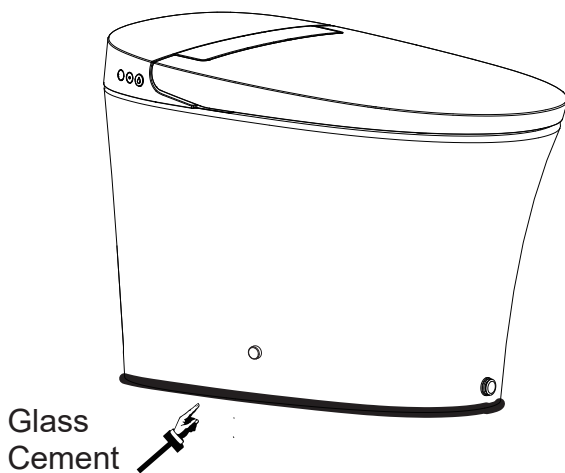

Tips:
Please make sure ceramic toilet outlet sits perfectly on drain outlet.

BEFORE INSTALLATION

1. Turn on the angle valve

Check thread connection, make sure no leakage is found, unscrew angle valve anticlockwise to maximum opening.
(Tips: When opening for the first time, the angle valve handle has a larger torque)

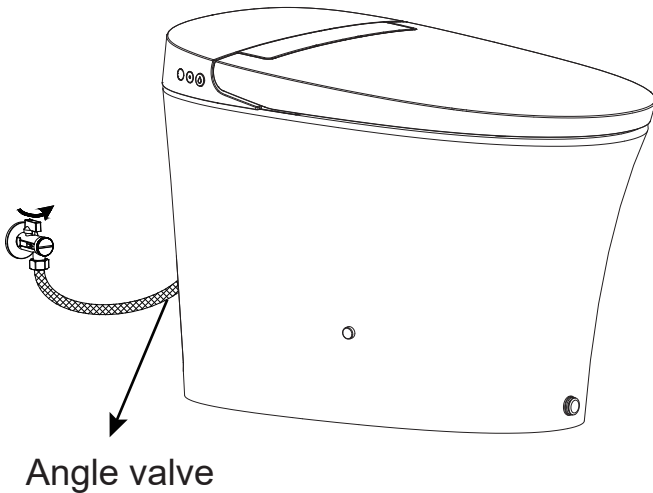

2. Power Connection

Take out the battery box from the accessory kit and install 4pcs 1.5V "AA" alkaline batteries. Plug the DC plug of battery box into the DC socket of toilet and then stick the battery box to the Velcro on the bottom of the toilet.

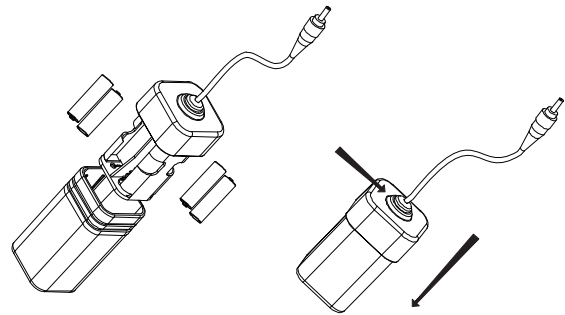

⚠ Caution

When re-installing the cover of battery box, use your fingers to squeeze the side of rubber plug to exhaust air out of the box and ensure sealing.

3. Self-inspection

After the batteries are successfully installed, the red indicator light will flash once.

Notes:

1. Must be 1.5V "AA" alkaline battery;
2. Different brands, different used and new batteries cannot be mixed.
3. Battery life will be significantly reduced when using non-alkaline batteries;
4. When installing the inner box components, follow the installation direction shown in the label.

INSTALLATION

Adhesive Fixing

- First connect the battery box (with batteries installed) to the main unit.

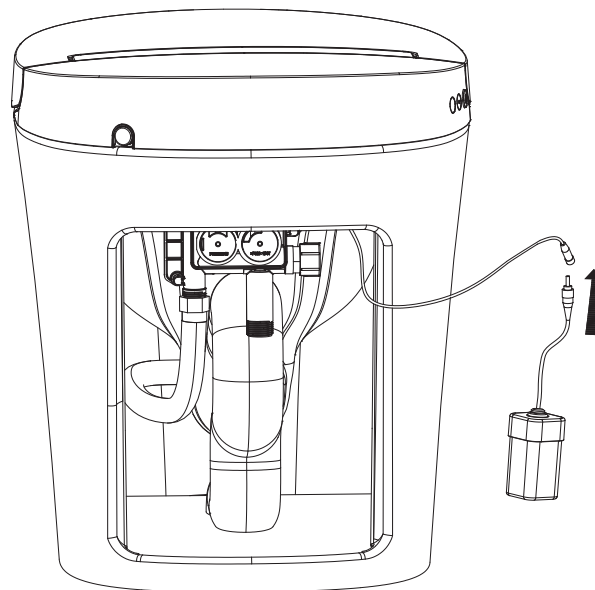

Daily maintenance

Use only a soft, damp cloth to clean.
Avoid using harsh chemicals.

Note:

If the toilet is with off-seat auto flushing function, it may activate auto flushing during the cleaning.

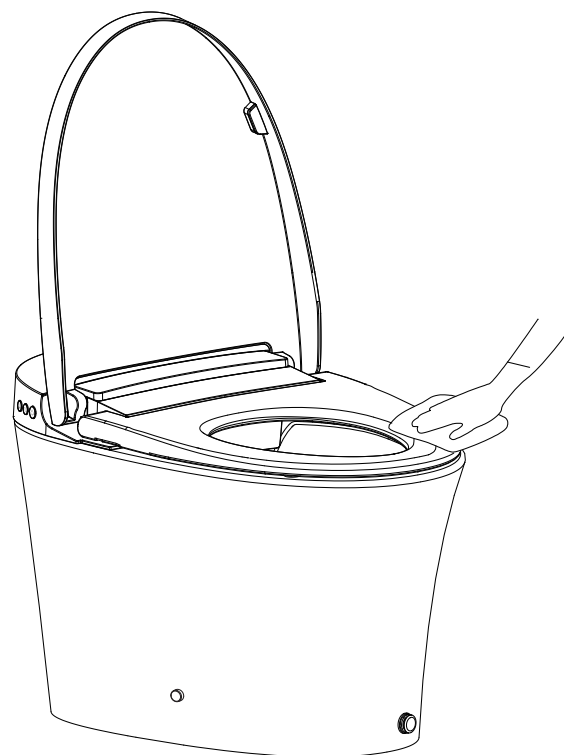
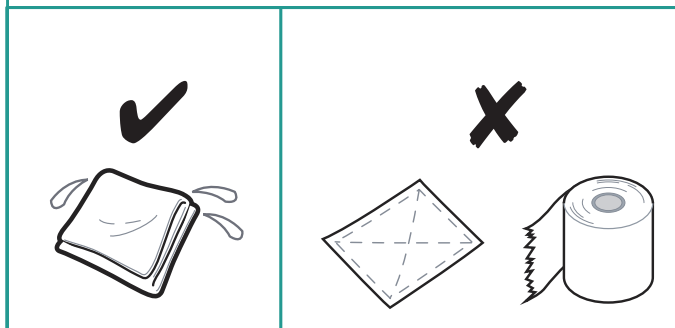

Maintenance of filter net

1. Turn off power and the angle valve
2. Unscrew angle valve nut
3. Remove filter net
4. Use the brush to clean filter net
5. Reinstall filter and angle valve hut, turn on the angle valve and connect power, then it can work normally after self inspection.

Time for maintenance: It is under normal water pressure but poor flush performance occurs.

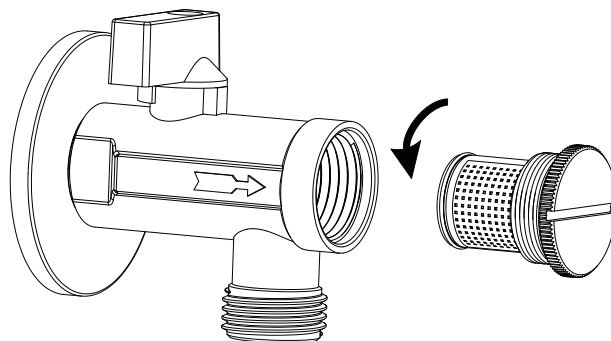

Emergency Troubleshooting

No water supply

- Put around 8L water into a barrel and flush the bowl of ceramic.

Note: Avoid water spilling from bowl.

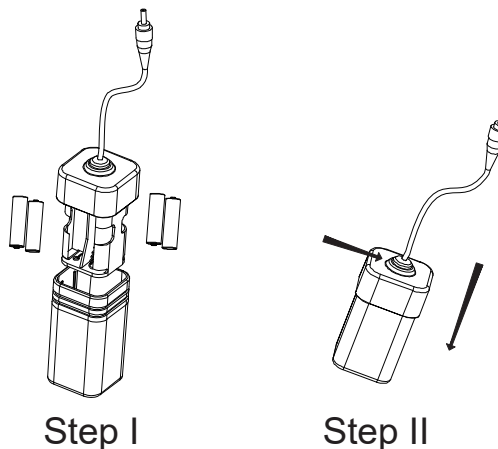
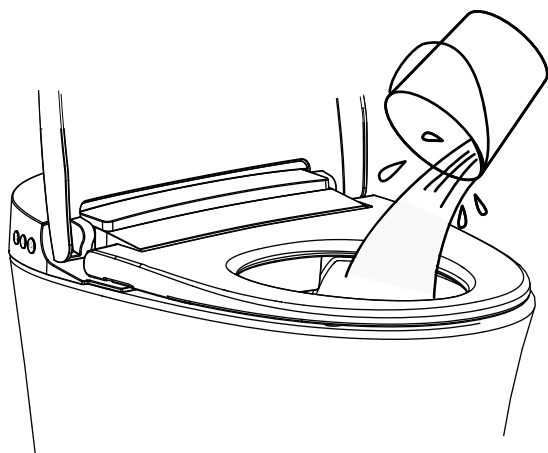

Unscrew the screws on the back cover and remove back cover from the control module, replace batteries and tighten the screws again. Pay attention to inner box direction when installing.

Replacement of battery

- Unplug the DC plug of the battery box and remove the battery box from the bottom of the toilet.
- Remove the cover of battery box and replace old batteries with new batteries, and then re-install the cover.
- Insert the DC plug of battery box into the DC socket of toilet and then stick the battery box to the Velcro on the bottom of the toilet.

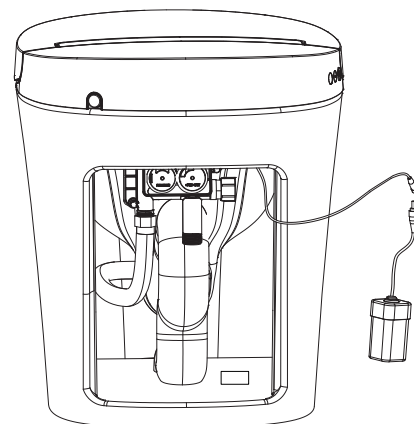

When the product is left unused for long time

- Especially in winter when no one at home for a long time, please drain out the water inside tank and pipe to prevent freezing.

To discharge water

1. Drain out the water inside tank
 - Activate flushing, and then turn off angle valve to prevent water inlet.
2. Unplug and remove the battery box and then remove all batteries.
3. Drain out the water inside pipe
 - Unscrew the hose connector off angle valve, drain the water in the pipe and reinstall.
4. Handle the remaining water in bowl
 - It is suggested to put some antifreeze into water inside the bowl.

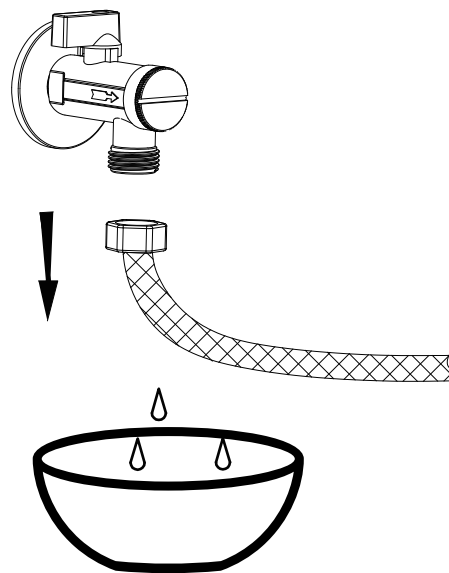

When using the toilet again, re-connect the water supply and re-install the battery box.

Caution

Before water discharging, the power must be cut off!

Technical Specification

Model		W5100
Main Unit	Rated Voltage	DC:6V
	Rated Power	2.1W
	IP Rating	IPX4
Toilet	Flush volume	Full flush 6.0L/Half flush 4.1L
	Flush Type	Siphonic jet
	Waste Outlet	S-trap 305mm
	Outlet outside diameter	88mm
	Water pressure range	0.09MPa (dynamic water pressure, flow rate 15.0 L/min or more)--0.8MPa (static water pressure)
	Installation method	Glass cement/ foundation bolts
Seat	Open and close device	Quiet soft-closing device
Caring device	Automatic flushing	Toilet will automatically flush as user walks away from bowl
	Low battery indication	If the battery is low, when pressing the flush button, the indicator light will flash, indicating batteries need to be replaced.
	Foot-touch flushing function	Kick the foot-touch button to flush (optional)
	Antibacterial position	Seat

The illustration of Main Unit Buttons

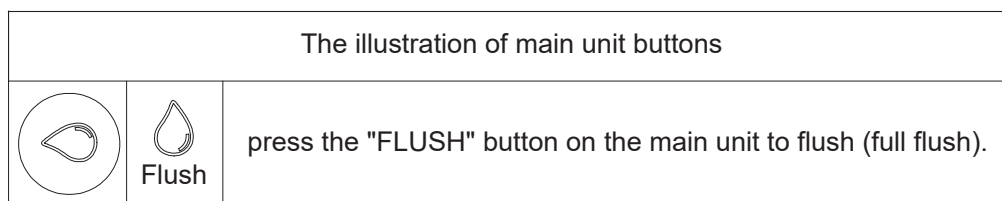

Notes:

1. Button light: If the battery is low, when pressing the flush button, the red light will flash.
2. Off-seat auto flushing: In the off-seat auto flushing mode, if a user is seated for $\geq 6s$ and ≤ 1 min, and leaves the seat for $>3s$, the toilet will activate a half flush. If a user is seated for 1 min, and leaves the seat for $>3s$, the toilet will activate a full flush.



206 WEMBLY ROAD - NEW WINDSOR, NY 12553
P: 718.602.6060 F: 718.963.2082 - E: INFO@FINEFIXTURES.COM
TOLL FREE: 1.877.8FIXTURES
FINEFIXTURES.COM

